

BETA

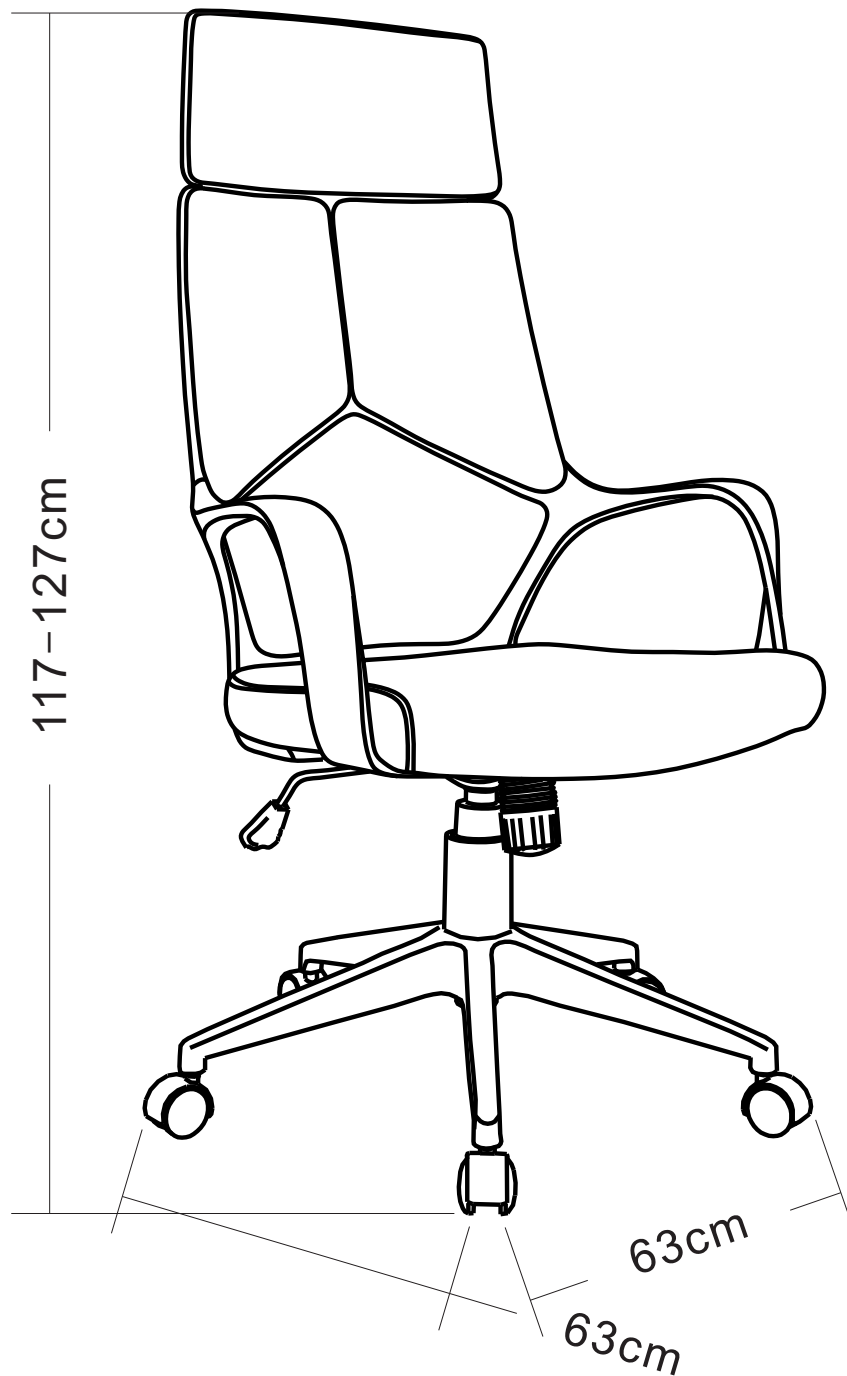

N: Viktig; Les nøye og oppbevar for bruk senere.

D: Wichtig! Sorgfältig lesen und für spätere Verwendung aufbewahren.

UK: Important! Read carefully and retain for future reference.

F: Important! A lire soigneusement et à conserver.

SE: Viktigt : Läs noggrant och spara för senare behov.

ES: Importante. Leer cuidadosamente las instrucciones y guardar para futuras referencias.

I: Importante! Leggere attentamente e conservare per future necessità.

N: For å unngå at møbelet får skader under montering anbefales det å montere møbelet på et mykt underlag, f.eks. på et teppe.

UK: Assembling of the furniture should take place on a soft surface e.g.a carpet in order to avoid scratching during assembly.

D: Um zu vermeiden, dass das Möbelstück gerissen wird, empfehlen wir unbedingt, es auf einer weichen Unterlage zu montieren - z.B. ein Teppich.

F: Afin d'éviter les rayures lors du montage, l'assemblage du meuble doit être effectué sur une surface douce - par exemple une couverture.

SE: För att möbelen inte ska repas vid montering bör den monteras på ett mjukt underlag - tex. på en matta.

ES: El montaje del sofa tiene que ser hecho en una superficie suave, como por ejemplo una alfombra o una manta, para evitar rozaduras durante el montaje.

I: Il montaggio dei mobili dovrebbe essere eseguito su una superficie morbida, ad esempio su un tappeto, per evitare rigature dovute all'assemblaggio.

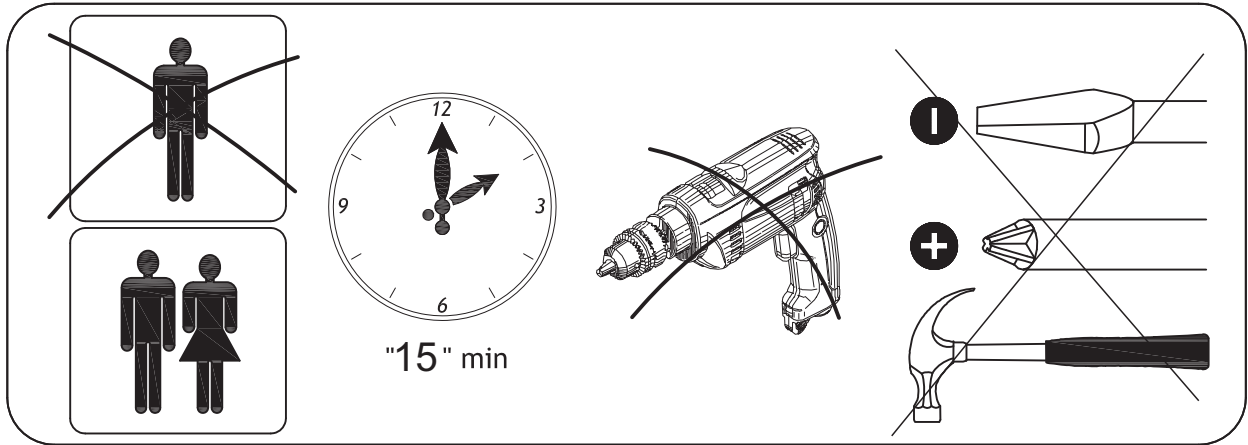
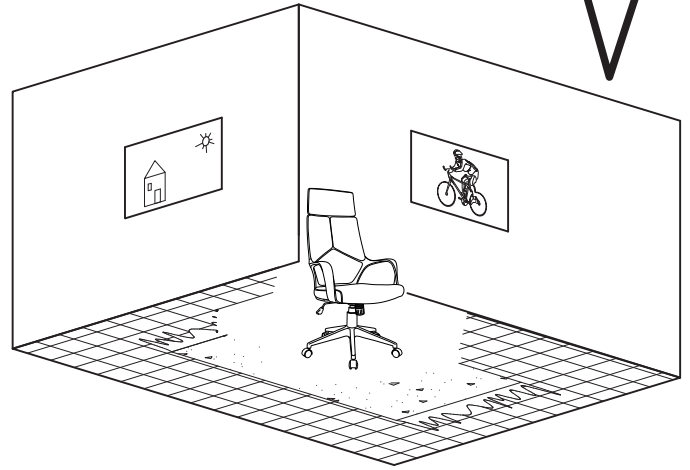

mm

10

20

30

40

50

60

70

80







90

100

110

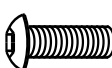
120

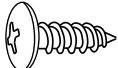
Hardware

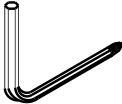
(A) ×4  M6*20mm	(B) ×6  M6*25mm	(C) ×4  M6*35mm	(D) ×4  M6*16mm
(E) ×4  M5*18mm	(F) ×10  Φ 15*Φ 6*1.5mmT	(G) ×1 	

N: Dersom det skulle være nødvendig å bestille reservedeler, vennligst oppgi både modell- og delenummer.

D: Falls Sie Ersatzteile benötigen, geben Sie bitte Modellnummer und Teilnummer, die Sie in der Montageanleitung findet an.

UK: In case you need spare parts please indicate model number and part number shown in the assembly instruction.

F: Dans le cas où vous auriez besoin de pièces détachées, nous vous prions de bien vouloir indiquer la référence du produit et celle de la pièce en question.

SE: Om det blir nödvändigt att beställa reservdelar, var vänlig uppgi både modellnummer och det angivna numret på reservdelen.

ES: En caso de que usted necesite alguna pieza de cambio, por favor, indicar modelo y número conforme aparece en las instrucciones.

I: Nel caso in cui siano necessarie delle parti di ricambio, indicare il numero del modello e il numero della parte indicati nelle istruzioni di montaggio.



1

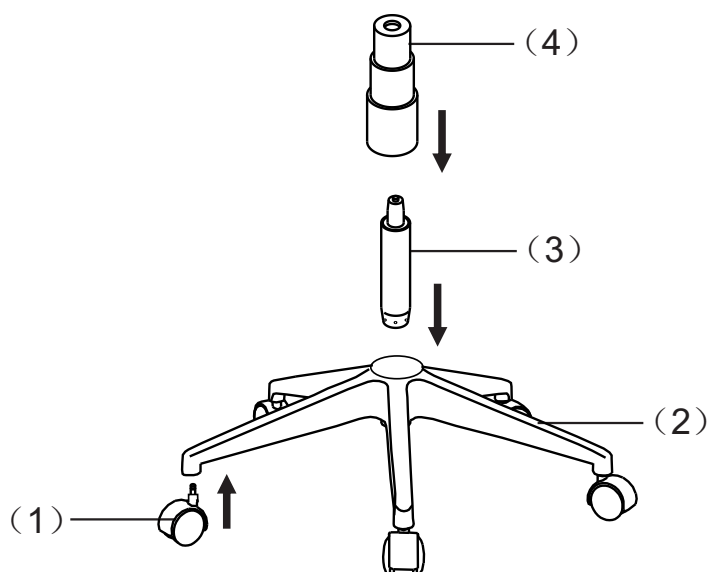

2

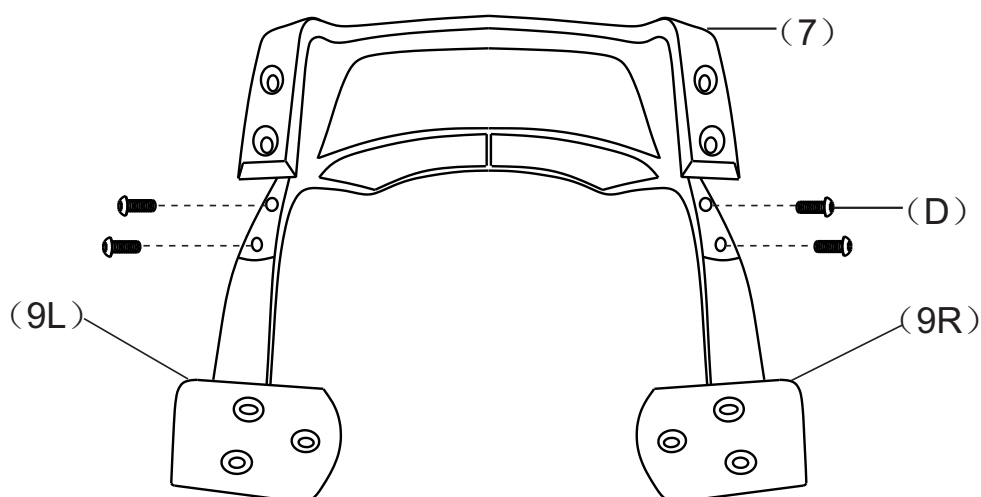
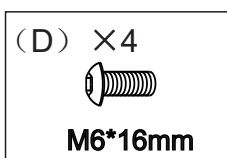

N: Dersom det skulle være nødvendig å bestille reservedeler, vennligst oppgi både modell- og delenummer.

D: Falls Sie Ersatzteile benötigen, geben Sie bitte Modellnummer und Teilnummer, die Sie in der Montageanleitung findet an.





UK: In case you need spare parts please indicate model number and part number shown in the assembly instruction.

F: Dans le cas où vous auriez besoin de pièces détachées, nous vous prions de bien vouloir indiquer la référence du produit et celle de la pièce en question.

SE: Om det blir nödvändigt att beställa reservdelar, var vänlig uppgi både modellnummer och det angivna numret på reservdelen.

ES: En caso de que usted necesite alguna pieza de cambio, por favor, indicar modelo y número conforme aparece en las instrucciones.

I: Nel caso in cui siano necessarie delle parti di ricambio, indicare il numero del modello e il numero della parte indicati nelle istruzioni di montaggio.

(A) ×4  M6*20mm	(B) ×6  M6*25mm	(C) ×4  M6*35mm	(F) ×10  Φ15*Φ6*1.5mmT
--	--	--	---

3

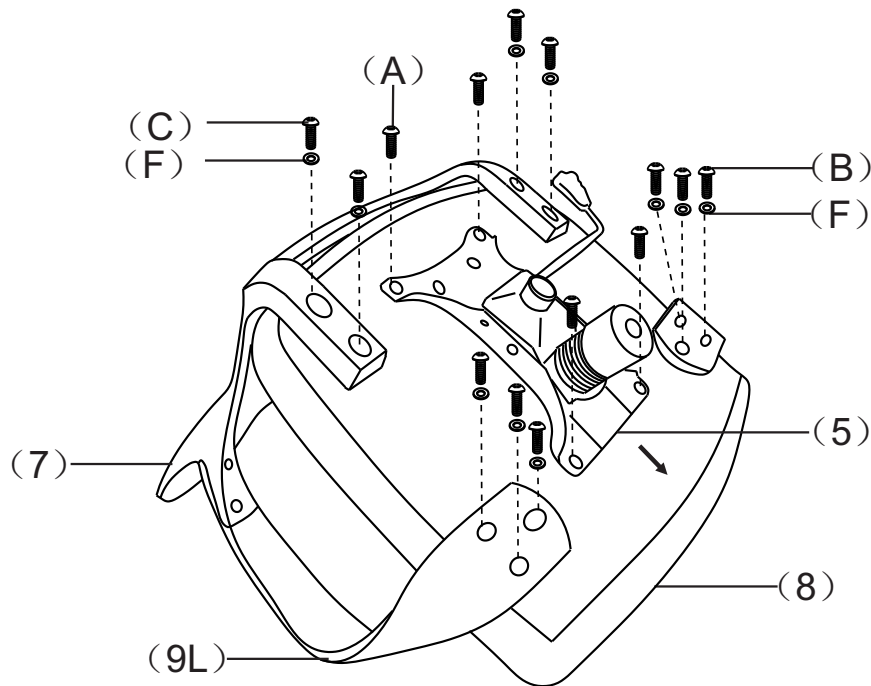

4

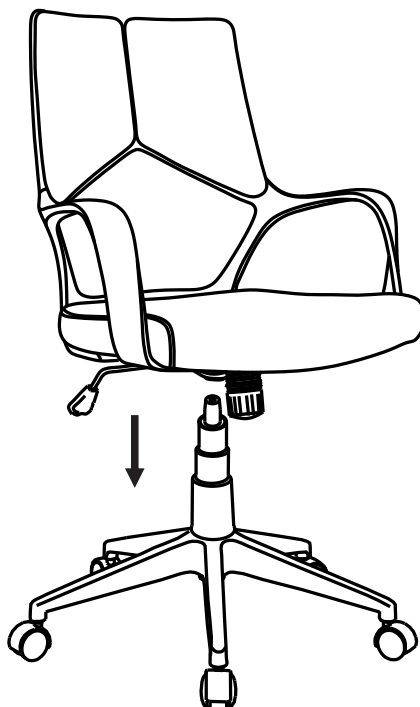

5

(E) ×4

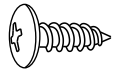

M5*18mm

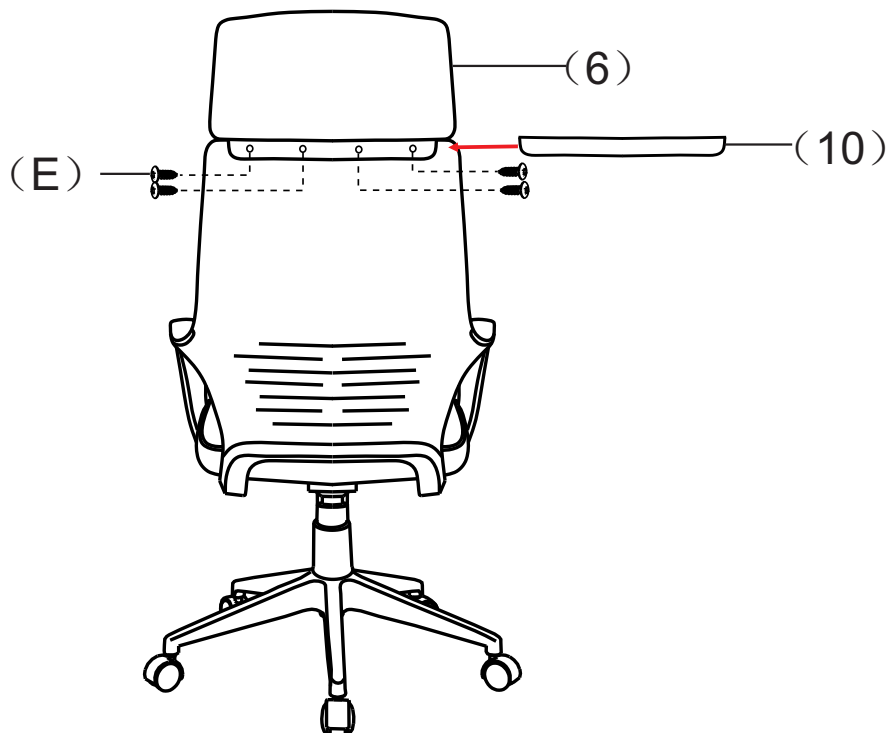

6

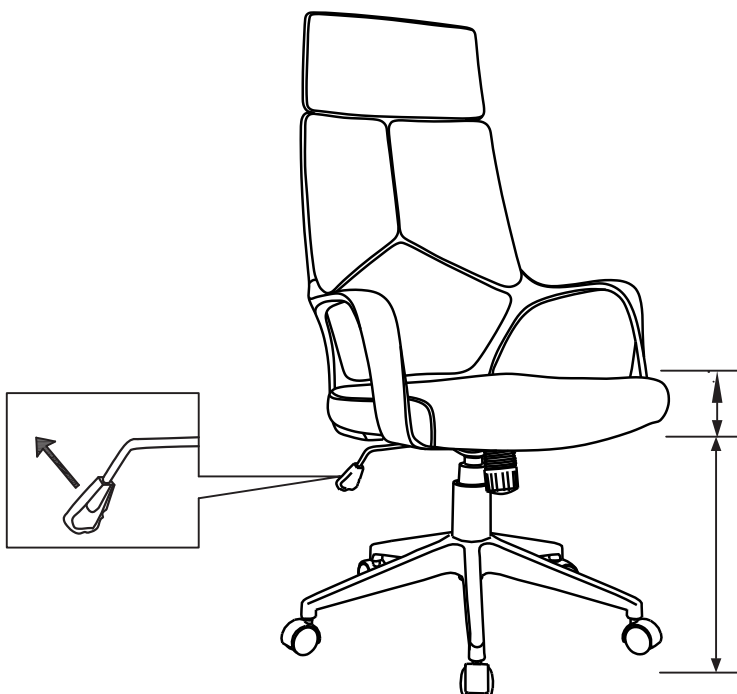

UK

Use the lever on right hand side under the seat to adjust the high of the seat by pressing the lever up or down wards.

NO

Bruk hendelen på høyre side av setet for å justere høyden.

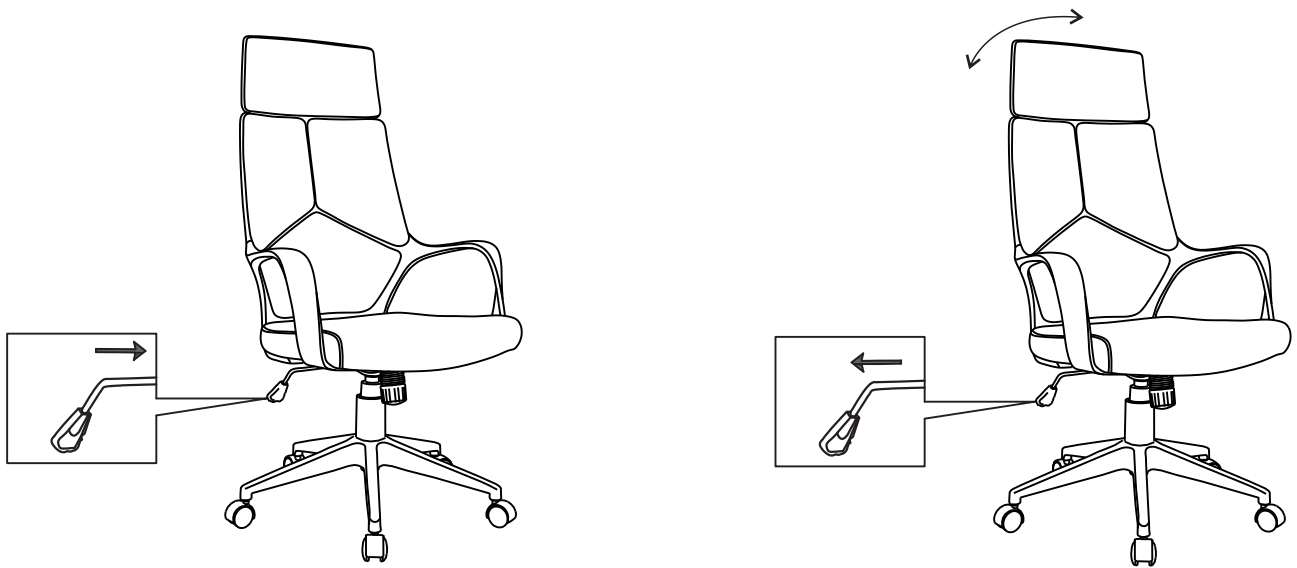

UK

The Seat can be used in a locked or free floating setting. Use the lever on the right hand side under the seat. Push the lever to the left to lock it. Push the level to the right to allow free float.

NO

Setetposisjonen kan låses eller beholdes fleksibel. Bruk spaken på høyre side under setet. Trykk spaken innover for å låse posisjonen eller dra den ut for å frigjøre.

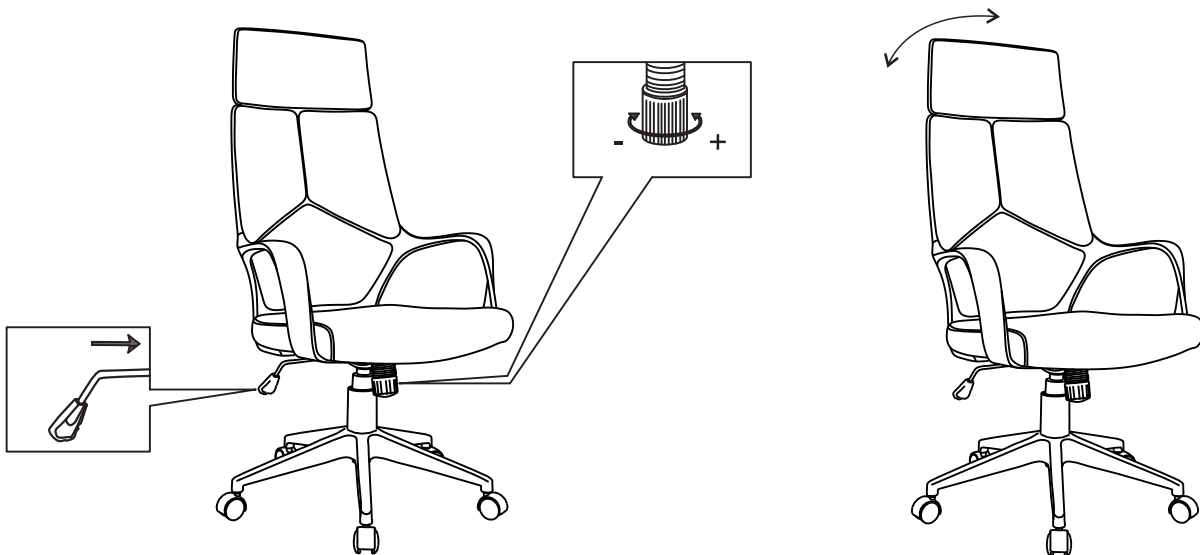

UK

When using the chair in the free float position it is possible to adjust the pressure required to move back and forth. Use the control placed centrally under the seat. Turn this control to your desired tension in direction of +/- sign.

NO

Når setet er i fri-posisjon, kan du justere motstanden ved å stramme eller løsne det runde hjulet under setet.

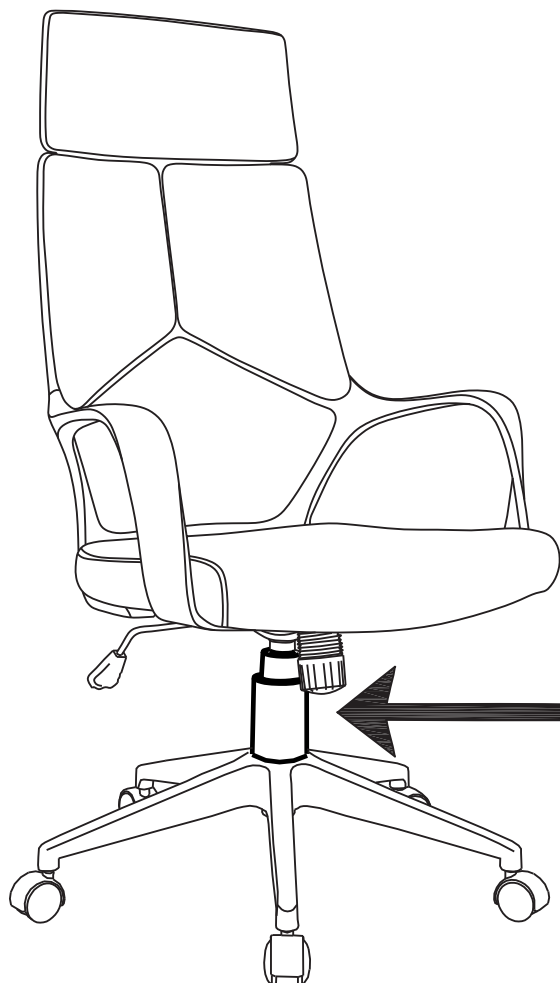

UK: Do not try to replace or repair

NO: Denne delen kan ikke byttes ut eller repareres.

UK

Use this product only for seating one person at a time.

This chair is intended to be used on hard floors. We always recommend that the chair is placed on a protective floor plate

The Seat can be cleaned using a soft damp cloth

NO

Dette produktet er kun beregnet til bruk av én person om gangen.

Stolen er beregnet for harde gulv (tre, gulvbelegg, betong).

Det anbefales alltid bruk av beskyttelsesmatte for å unngå skader på underlaget.

Rengjøres med fuktig klut eller egnede rense- og impregneringsmidler.

Spør betjening ved utsalgssted.